

# PLC1602HW SERIES (16CH \* 2L)



龐誼科技股份有限公司

Palm Technology Co., Ltd.

## EXTERNAL DIMENSION

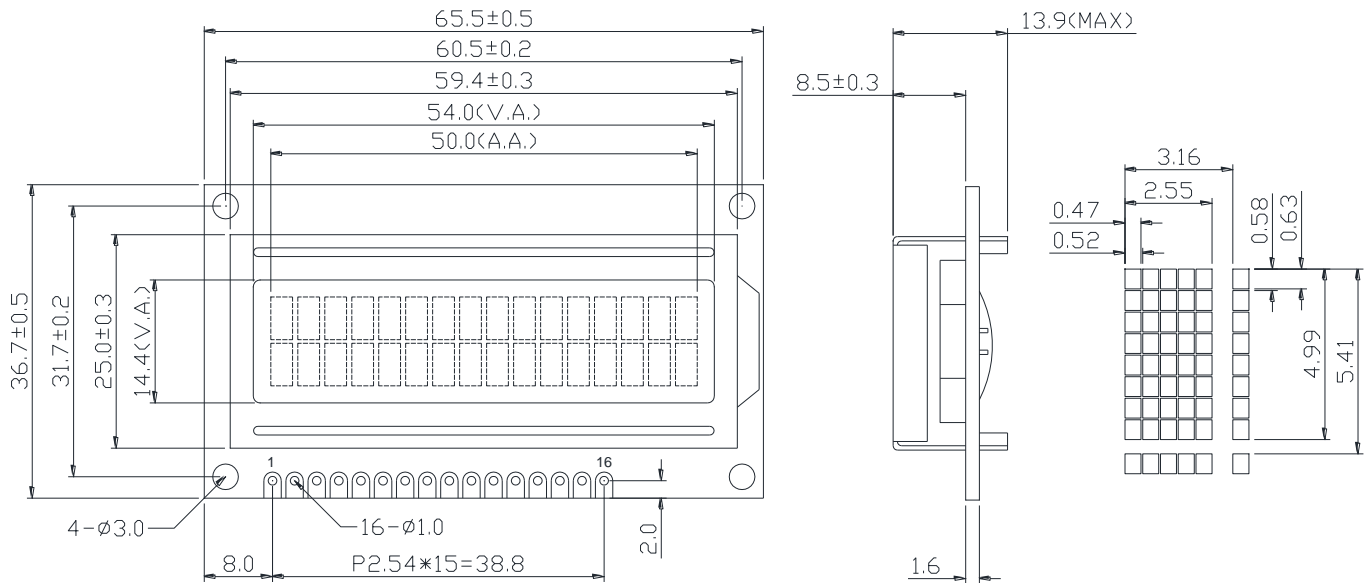

### Feature:

1. Driving: Duty: 1/16, 1/5 Bias, VLCD: 4.3V
2. Driver : SPLC780D VDD: 5.0 V
3. Operating temp. :  $-20^{\circ}\text{C} \sim +70^{\circ}\text{C}$   
Storage temp. :  $-25^{\circ}\text{C} \sim +75^{\circ}\text{C}$
4. ROHS Compliant

## PIN CONNECTIONS

<b>PIN NO</b>	<b>1</b>	<b>2</b>	<b>3</b>	<b>4</b>	<b>5</b>	<b>6</b>	<b>7</b>	<b>8</b>
<b>SYMBOL</b>	<b>VSS</b>	<b>VDD</b>	<b>V0</b>	<b>RS</b>	<b>R/W</b>	<b>E</b>	<b>DB0</b>	<b>DB1</b>
<b>PIN NO</b>	<b>9</b>	<b>10</b>	<b>11</b>	<b>12</b>	<b>13</b>	<b>14</b>	<b>15</b>	<b>16</b>
<b>SYMBOL</b>	<b>DB2</b>	<b>DB3</b>	<b>DB4</b>	<b>DB5</b>	<b>DB6</b>	<b>DB7</b>	<b>LED+</b>	<b>LED-</b>

## BLOCK DIAGRAM

