

PHC16011AW SERIES (16CH * 1L)

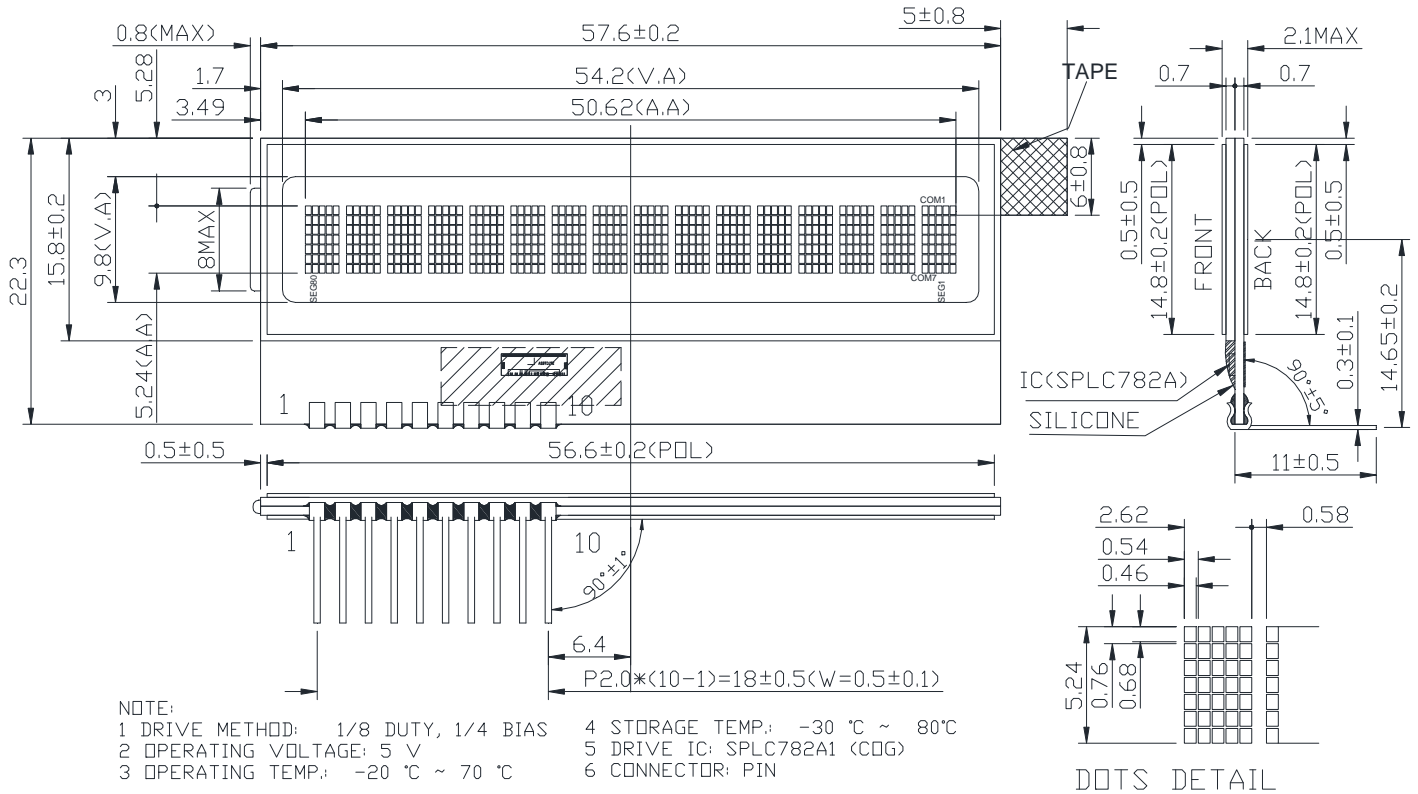

龐誼科技股份有限公司
Palm Technology Co., Ltd.

EXTERNAL DIMENSION



PIN CONNECTIONS

PIN NO	1	2	3	4	5	6	7	8	9	10
SYMBOL	DB7	DB6	DB5	DB4	E	R/W	RS	VPP	VDD	VSS

BLOCK DIAGRAM

